



ice line

MIGEL



SERIE **KFP**

FABBRICATORI DI GHIACCIO GRANULARE PRESSATO
MACHINES À GLACE EN GRAINS PRESSÉE
ICE FLAKE MACHINES - PRESSED ICE FLAKES
FABRICADORES DE HIELO GRANULAR PRENSADO
EISFLOCKENBEREITER - GEPRESSTE EISFLOCKEN

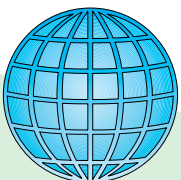

Fabbricatori di ghiaccio granulare serie KFP



La gamma dei fabbricatori di ghiaccio granulare pressato della serie KFP è composta da 8 modelli con produzione giornaliera compresa tra i 78 Kg, 125 Kg e i 170 Kg con contenitore incorporato; ed i modelli modulari da 180 Kg, 275 Kg, 510 Kg, 980 Kg e 1720 Kg; fabbricatori modulari combinabili con i contenitori B/BL100, B/BL150, B/BL250 e TF60/RB60 o altri.

Il ghiaccio granulare pressato della serie KFP è ideale per l'uso nei bar, laboratori, ospedali, panifici, macellerie, pescherie, fast food e ristoranti.

Un ghiaccio granulare con una temperatura ottimale (-0,5°C) asciutto, compatto e non tende ad impaccarsi.

Machines à glace en grains série KFP



La gamme de machines à glace en grains pressée série KFP est composée par 8 modèles avec une production journalière comprise entre 78 Kg, 125 Kg et 170 Kg, tous les deux avec le bac de conservation intégré; et les modèles modulaires de 180 Kg, 275 Kg, 510 Kg, 980 Kg et 1720 Kg; machines à glace en grains modulaires pour combinaison avec les bacs de conservation B/BF100, B/BF150, B/BF250 et TF60/RB60 ou d'autres.

La glace en grains pressée serie KFP est idéale pour bar, laboratoires, hôpitaux, boulangeries, boucheries, poissonneries, Fast Food et restaurants.

Une glace en grains avec une température idéale (-0,5°C), sèche, compacte qui ne s'empâte pas.

Ice flake machines series KFP



The range of ice flake machines series KFP-pressed ice flakes consists of 8 models with a daily production between 78 Kg/172 Lb, 125 Kg/275 lb and 170 Kg/374 Lb all with built in storage bin; and the modular models 180 Kg/396 Lb, 275 Kg/510 Lb, 490 Kg/1120 Lb 980 Kg/2156 Lb and 1720 Kg/3870 Lb; modular ice-flake machines to combine with the storage bin B/BF100, B/BF150, B/BF250 and TF60/RB60 or others.

The pressed ice flake of series KFP is ideal for bar, laboratories, hospitals, bakeries, butchers, fishmongers, Fast Food outlets and restaurants.

An ice flake with a perfect temperature (-0,5°C) produced dry and compact.

Fabricadores de hielo granular serie KFP



La gama de fabricantes de hielo granular prensado serie KFP está compuesta por 8 modelos con producción diaria comprendida entre 78 Kg, 125 Kg y 170 Kg con depósito incorporado; y los modelos modulares de 180 Kg, 275 Kg, 510 Kg, 1120 Kg y 1720 Kg; modulares combinables con los depósitos B/BF100, B/BF150, B/BF250 y TF60/RB60.

El hielo granular prensado ideal para bar, laboratorios, hospitales, panificadores, carnicerías, pescaderías, Fast Food y restaurantes. El hielo granular es seco, compacto, con tendencia a no comprimirse y con temperatura óptima (-0,5°C).

Eisflockenbereiter Serie KFP



Die Produktgruppe der Eisflockenbereiter Serie KFP gepresste Eisflocken besteht aus 8 Modellen mit Tagesleistungen von 78 Kg, 125 Kg und 170 Kg, mit eingebautem Behälter; und den Modulen, 180 Kg, 275 Kg, 510 Kg, 980 Kg und 1720 Kg; Bereiter im Modulbausystem kombinierbar mit den Behältern B/BF100, B/BF150, B/BF250 und TF60/RB60 oder anderen.

Die gepresste Eisflocke der Serie KFP ist ideal für den Gebrauch in Bar, Laboratorien, Krankenhäusern, Bäckereien, Fleischereien, Fischhandel, Fast Food und Restaurants. Eine Eisflocke mit einer optimalen Temperatur (-0,5°C), trocken, kompakt und nicht matschig.

Caratteristiche Generali

- Produzione continua
- Controllo elettronico del funzionamento (modulari)
- Carrozzeria in acciaio inox (AISI 304)
- Raffreddamento ad aria (A) o ad acqua (W)
- KFP85 con ventilazione frontale per l'incasso a richiesta (Mod. F)
- Interruttore generale (ON/OFF)
- Trasmissione a cinghia
- Costi di esercizio ridotti, consumi di elettricità ed acqua bassi
- Ingombro ridotto
- Massima accessibilità alla componentistica
- Refrigerante R290/R404A/R452A

Caractéristiques Générales

- Production continue
- Contrôle électronique du fonctionnement (modulaires)
- Carrosserie en acier inoxydable (AISI 304)
- Refroidissement par air (A) ou par eau (W)
- KFP85 avec ventilation frontale pour encastrement (Mod. F)
- Interrupteur général (ON/OFF)
- Transmission par courroie
- Réduits coûts d'exercice, réduite consommation d'électricité et d'eau
- Dimensions réduites
- Composants facilement accessibles
- Réfrigérant R290/R404A/R452A

General Specifications

- Continuous production
- Electronic function control (modular flakers)
- Stainless steel bodywork (BS 304 S01)
- Condensing units air cooled (A) or water cooled (W)
- KFP85 with frontal ventilation for boxing in (Mod. F)
- Main switch (ON/OFF)
- Belt drive system
- Low power and water consumption
- Reduced dimensions
- Maximum accessibility to components
- Refrigerant R290/R404A/R452A

Características Generales

- Producción continua
- Controles electrónicos de funcionamiento (modulares)
- Carrocería en acero inoxidable (AISI 304)
- Condensación por aire (A) o por agua (W)
- KFP85 con ventilación frontal bajo barra (Mod. F)
- Interruptor general (ON/OFF)
- Transmisión por correa
- Reducido coste de fabricación, consumos eléctricos y de agua bajos
- Dimensiones reducidas
- Máxima accesibilidad sobre lo componentes
- Refrigerante R290/R404A/R452A

Generelle Eigenschaften

- Kontinuierliche Eisproduktion
- Elektronische Steuerung (Module)
- Chromnickelstahl Gehäuse (AISI 304)
- Luftkühlung (A) oder Wasserkühlung (W)
- KFP85 mit Frontbelüftung für den Einbau auf Anfrage (Mod. F)
- Hauptschalter (Ein/Aus)
- Keilriemenantrieb
- Reduzierte Betriebskosten durch eingeschränkten Strom- und Wasserverbrauch
- Reduzierte Ausmaße
- Leicht erreichbare Komponenten
- Kältemittel R290/R404A/R452A



KFP 85

	A	W
Produzione • Production • Production Produccion • Tagesleistung	*Kg/24h Lb/24h	75 78 165 172
Capacità contenitore • Capacité bac • Bin capacity Capacidad del deposito • Behälterkapazität	Kg - Lb	25 - 55
Assorbimento • Consommation • Power Potencia • Leistungsaufnahme	(T=43°C)-W	400
Peso netto • Poids net • Net weight Peso neto • Nettogewicht	Kg	57
Peso lordo • Poids brut • Gross weight Peso bruto • Bruttogewicht	Kg	61
Volume con imballo • Volume emballage • Volume packing Volume con embalage • Verpackungsvolumen	m ³	0,32
Refrigerante • Réfrigérant • Refrigerant Refrigerante • Kältemittel		R290
Voltaggio standard • Voltage standard • Standard voltage Voltage • Anschlußspannung		V230/50Hz/1

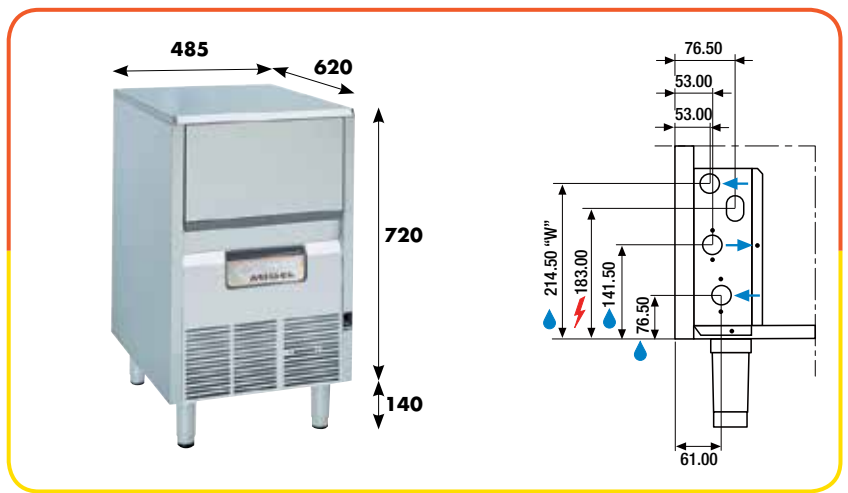

KFP 145

	A	W
Produzione • Production • Production Produccion • Tagesleistung	*Kg/24h Lb/24h	120 125 264 275
Capacità contenitore • Capacité bac • Bin capacity Capacidad del deposito • Behälterkapazität	Kg - Lb	42 - 92
Assorbimento • Consommation • Power Potencia • Leistungsaufnahme	(T=43°C)-W	450
Peso netto • Poids net • Net weight Peso neto • Nettogewicht	Kg	71
Peso lordo • Poids brut • Gross weight Peso bruto • Bruttogewicht	Kg	78
Volume con imballo • Volume emballage • Volume packing Volume con embalage • Verpackungsvolumen	m ³	0,54
Refrigerante • Réfrigérant • Refrigerant Refrigerante • Kältemittel		R290
Voltaggio standard • Voltage standard • Standard voltage Voltage • Anschlußspannung		V230/50Hz/1

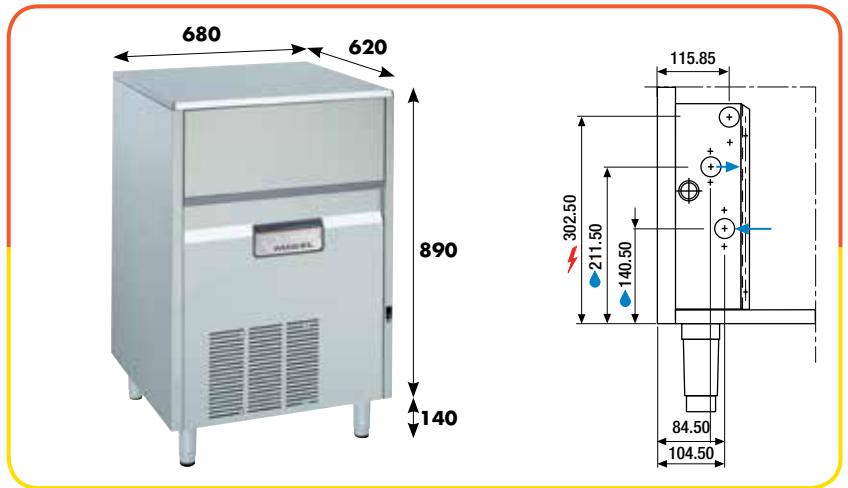

KFP 185

	A	W
Produzione • Production • Production Produccion • Tagesleistung	*Kg/24h Lb/24h	165 170 363 374
Capacità contenitore • Capacité bac • Bin capacity Capacidad del deposito • Behälterkapazität	Kg - Lb	60 - 132
Assorbimento • Consommation • Power Potencia • Leistungsaufnahme	(T=43°C)-W	690
Peso netto • Poids net • Net weight Peso neto • Nettogewicht	Kg	85
Peso lordo • Poids brut • Gross weight Peso bruto • Bruttogewicht	Kg	89
Volume con imballo • Volume emballage • Volume packing Volume con embalage • Verpackungsvolumen	m ³	0,63
Refrigerante • Réfrigérant • Refrigerant Refrigerante • Kältemittel		R290
Voltaggio standard • Voltage standard • Standard voltage Voltage • Anschlußspannung		V230/50Hz/1

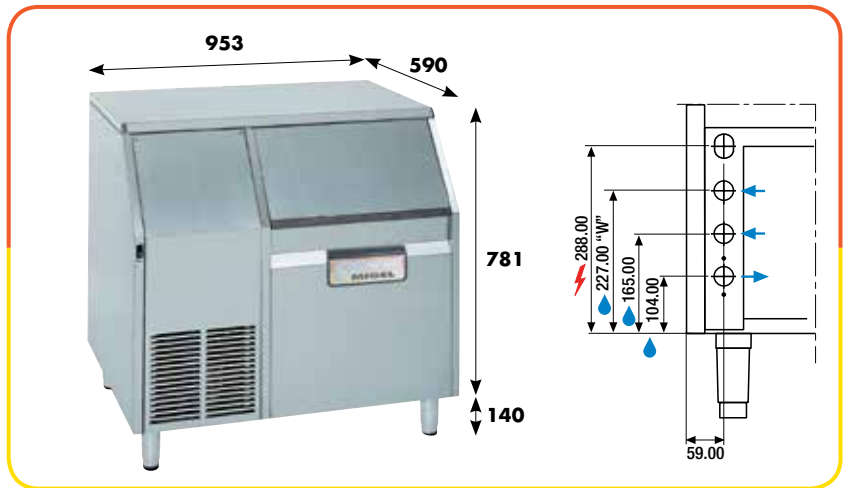

KFP 200

	A	W
Produzione • Production • Production Produccion • Tagesleistung	*Kg/24h Lb/24h	175 180 385 396
Capacità contenitore • Capacité bac • Bin capacity Capacidad del deposito • Behälterkapazität	Kg - Lb	-
Assorbimento • Consommation • Power Potencia • Leistungsaufnahme	(T=43°C)-W	720
Peso netto • Poids net • Net weight Peso neto • Nettogewicht	Kg	58
Peso lordo • Poids brut • Gross weight Peso bruto • Bruttogewicht	Kg	63
Volume con imballo • Volume emballage • Volume packing Volume con embalage • Verpackungsvolumen	m ³	0,30
Refrigerante • Réfrigérant • Refrigerant Refrigerante • Kältemittel		R290
Voltaggio standard • Voltage standard • Standard voltage Voltage • Anschlußspannung		V230/50Hz/1

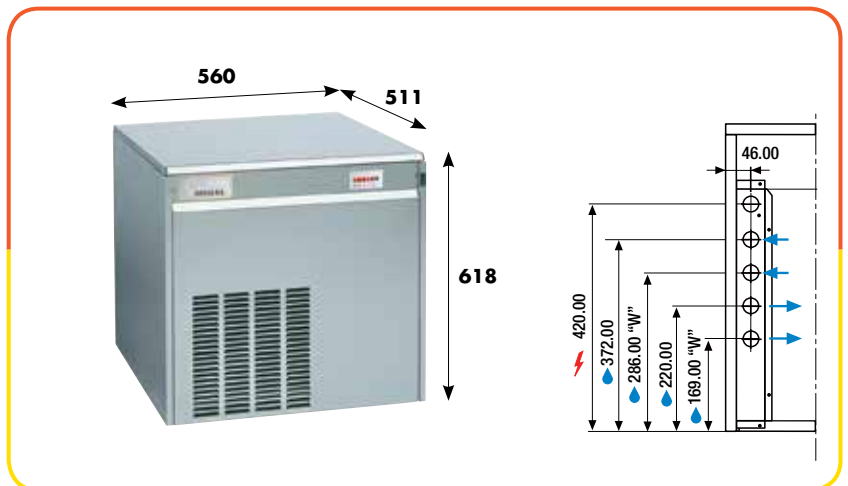



KFP 300

	A	W
Produzione • Production • Production Produccion • Tagesleistung	*Kg/24h Lb/24h	270 275 594 605
Capacità contenitore • Capacité bac • Bin capacity Capacidad del deposito • Behälterkapazität	Kg - Lb	-
Assorbimento • Consommation • Power Potencia • Leistungsaufnahme	(T=43°C)-W	920
Peso netto • Poids net • Net weight Peso neto • Nettogewicht	Kg	58
Peso lordo • Poids brut • Gross weight Peso bruto • Bruttogewicht	Kg	63
Volume con imballo • Volume emballage • Volume packing Volume con embalage • Verpackungsvolumen	m ³	0,30
Refrigerante • Réfrigérant • Refrigerant Refrigerante • Kältemittel		R290
Voltaggio standard • Voltage standard • Standard voltage Voltage • Anschlußspannung		V230/50Hz/1

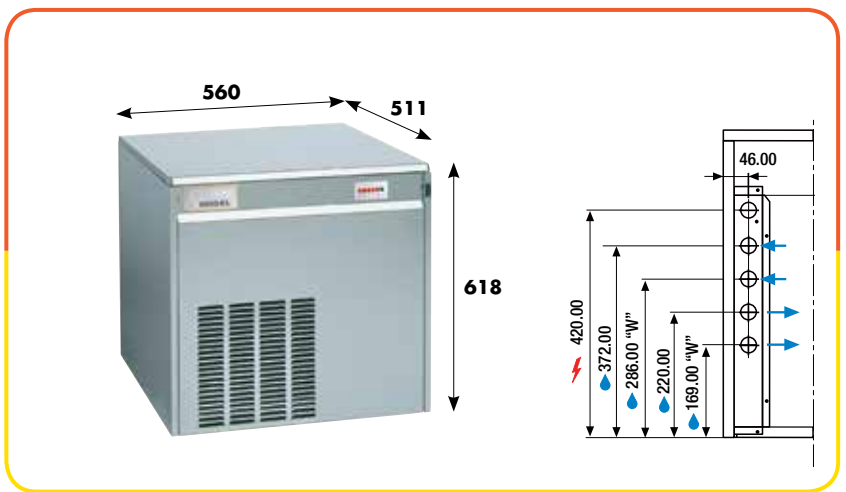

KFP 600

	A	W
Produzione • Production • Production Produccion • Tagesleistung	*Kg/24h Lb/24h	500 510 1100 1120
Capacità contenitore • Capacité bac • Bin capacity Capacidad del deposito • Behälterkapazität	Kg - Lb	-
Assorbimento • Consommation • Power Potencia • Leistungsaufnahme	(T=43°C)-W	1950
Peso netto • Poids net • Net weight Peso neto • Nettogewicht	Kg	111
Peso lordo • Poids brut • Gross weight Peso bruto • Bruttogewicht	Kg	115
Volume con imballo • Volume emballage • Volume packing Volume con embalage • Verpackungsvolumen	m ³	0,48
Refrigerante • Réfrigérant • Refrigerant Refrigerante • Kältemittel		R404A R452A
Voltaggio standard • Voltage standard • Standard voltage Voltage • Anschlußspannung		V230/50Hz/1

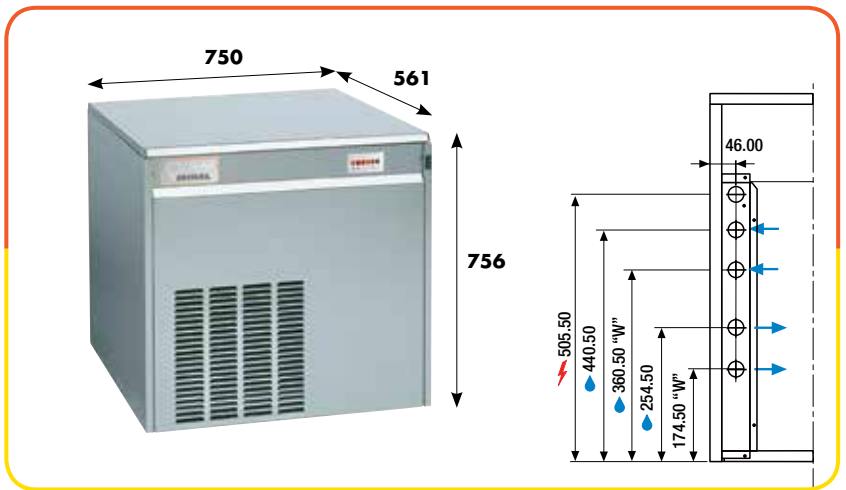

KFP 1200

	A	W
Produzione • Production • Production Produccion • Tagesleistung	*Kg/24h Lb/24h	970 980 2134 2156
Capacità contenitore • Capacité bac • Bin capacity Capacidad del deposito • Behälterkapazität	Kg - Lb	-
Assorbimento • Consommation • Power Potencia • Leistungsaufnahme	(T=43°C)-W	3600
Peso netto • Poids net • Net weight Peso neto • Nettogewicht	Kg	173
Peso lordo • Poids brut • Gross weight Peso bruto • Bruttogewicht	Kg	190
Volume con imballo • Volume emballage • Volume packing Volume con embalage • Verpackungsvolumen	m ³	0,76
Refrigerante • Réfrigérant • Refrigerant Refrigerante • Kältemittel		R404A R452A
Voltaggio standard • Voltage standard • Standard voltage Voltage • Anschlußspannung		V400/50Hz/3

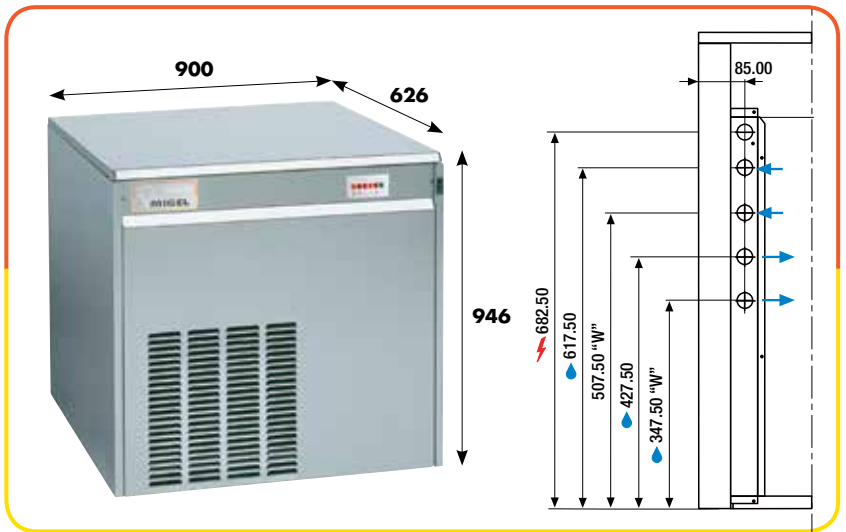

KFP 2500

	A	W
Produzione • Production • Production Produccion • Tagesleistung	*Kg/24h Lb/24h	1700 1720 3740 3870
Capacità contenitore • Capacité bac • Bin capacity Capacidad del deposito • Behälterkapazität	Kg - Lb	-
Assorbimento • Consommation • Power Potencia • Leistungsaufnahme	(T=43°C)-W	2x3600
Peso netto • Poids net • Net weight Peso neto • Nettogewicht	Kg	295
Peso lordo • Poids brut • Gross weight Peso bruto • Bruttogewicht	Kg	318
Volume con imballo • Volume emballage • Volume packing Volume con embalage • Verpackungsvolumen	m ³	1,40
Refrigerante • Réfrigérant • Refrigerant Refrigerante • Kältemittel		R404A R452A
Voltaggio standard • Voltage standard • Standard voltage Voltage • Anschlußspannung		V400/50Hz/3

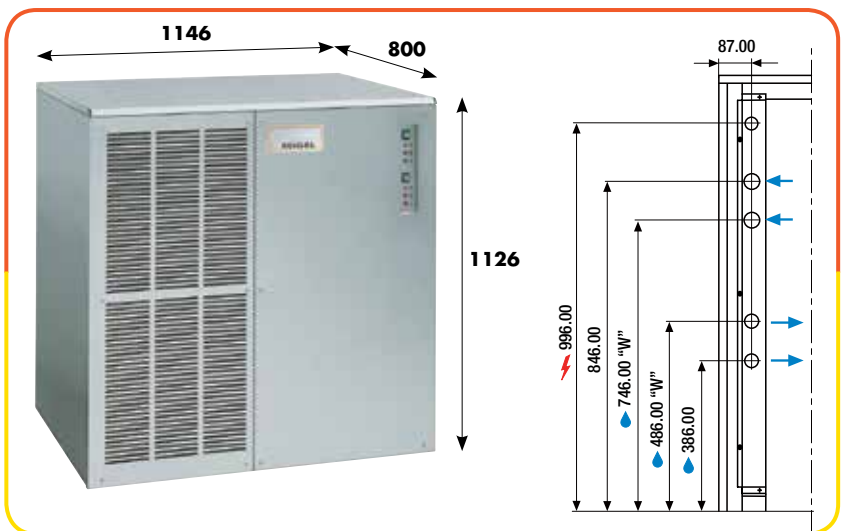



TF 60/RB 60

A W

Capacità contenitore • Capacité bac • Bin capacity Capacidad del deposito • Behälterkapazität	Kg - Lb	60 - 132
Peso netto • Poids net • Net weight Peso neto • Nettogewicht	Kg	47
Peso lordo • Poids brut • Gross weight Peso bruto • Bruttogewicht	Kg	51
Volume con imballo • Volume emballage Volume packing • Volume con embalage Verpackungsvolumen	m ³	0,54

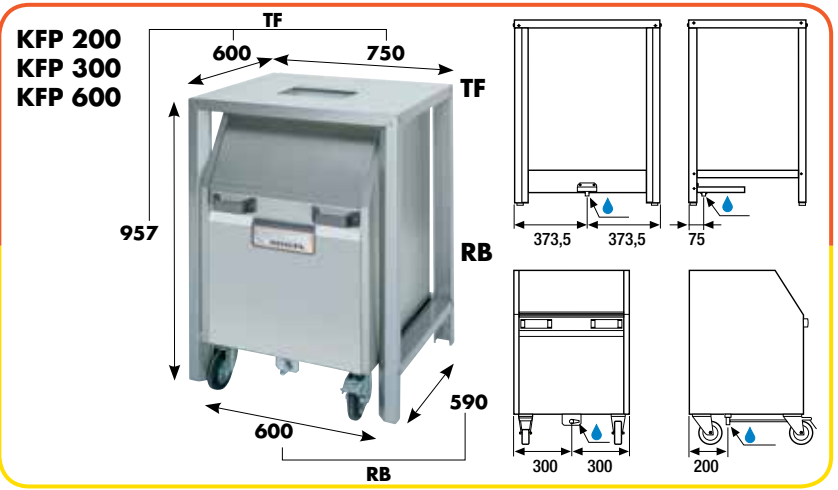

B 100/BF 100

A W

Capacità contenitore • Capacité bac • Bin capacity Capacidad del deposito • Behälterkapazität	Kg - Lb	100 - 220
Peso netto • Poids net • Net weight Peso neto • Nettogewicht	Kg	31
Peso lordo • Poids brut • Gross weight Peso bruto • Bruttogewicht	Kg	38
Volume con imballo • Volume emballage Volume packing • Volume con embalage Verpackungsvolumen	m ³	0,54

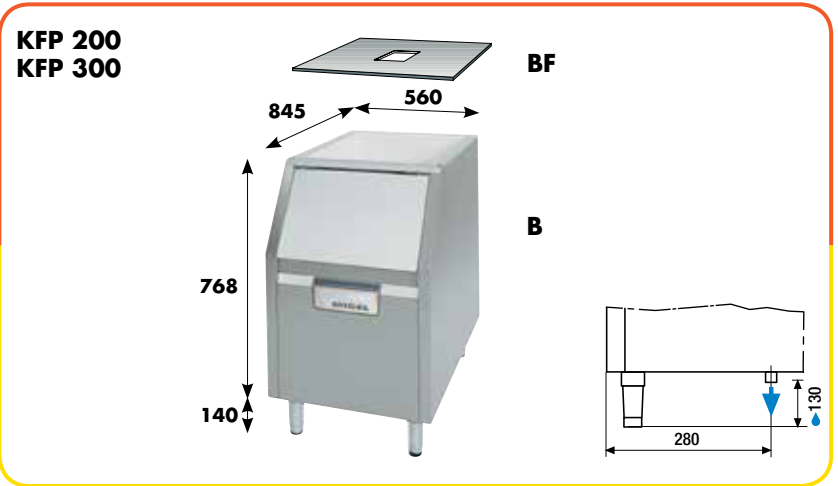

B 150/BF 150

A W

Capacità contenitore • Capacité bac • Bin capacity Capacidad del deposito • Behälterkapazität	Kg - Lb	150 - 330
Peso netto • Poids net • Net weight Peso neto • Nettogewicht	Kg	49
Peso lordo • Poids brut • Gross weight Peso bruto • Bruttogewicht	Kg	55
Volume con imballo • Volume emballage Volume packing • Volume con embalage Verpackungsvolumen	m ³	0,90

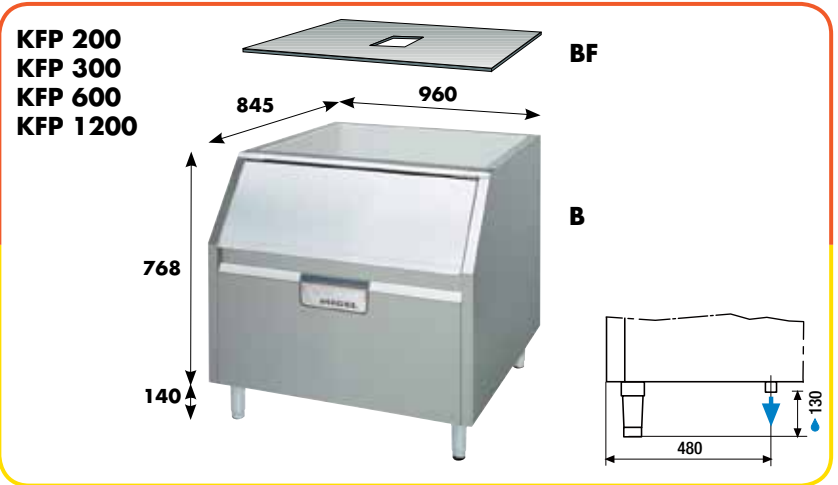

B 250/BF 250

A W

Capacità contenitore • Capacité bac • Bin capacity Capacidad del deposito • Behälterkapazität	Kg - Lb	250 - 550
Peso netto • Poids net • Net weight Peso neto • Nettogewicht	Kg	62
Peso lordo • Poids brut • Gross weight Peso bruto • Bruttogewicht	Kg	68
Volume con imballo • Volume emballage Volume packing • Volume con embalage Verpackungsvolumen	m ³	1,09

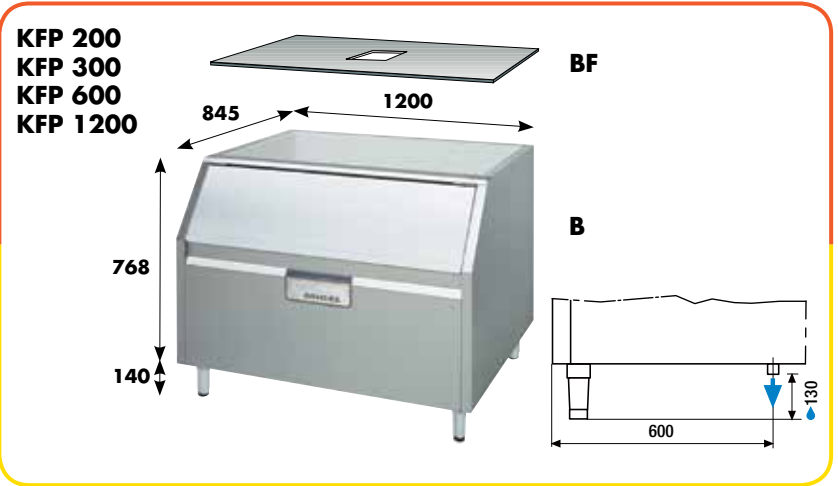

MIGEL KFP

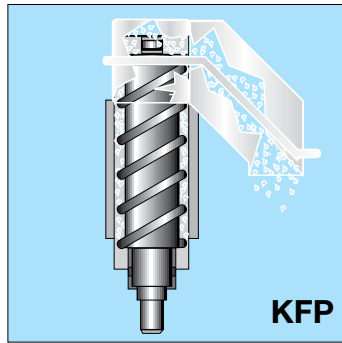

FILTER
a richiesta
sur demande
on request
a petición
auf Anfrage

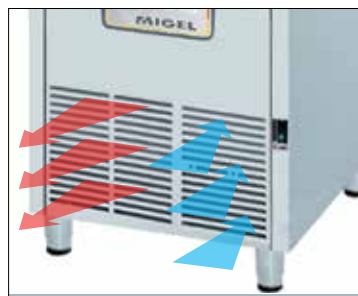

KFP 85

a richiesta • sur demande • on request
a petición • auf Anfrage



Attenzione:
Le produzioni nelle 24h si intendono ad una temperatura ambiente +10°C e una temperatura acqua +10°C. Il voltaggio standard è V230/50Hz monofase. Altri voltaggi come V230/60Hz e V115/60Hz monofase a richiesta.
I modelli e le caratteristiche possono subire modifiche senza preavviso.

Attention:
Les productions dans les 24 heures s'entendent à une température ambiante de +10°C et à une température de l'eau de +10°C. Le voltage standard est de 230V/50Hz monophasé.
Sur demande, possibilité de fourniture d'autres voltages comme le 230V/50Hz et le 115V/60Hz monophasé. Les modèles et les caractéristiques peuvent subir des modifications sans préavis.

Important:
24h production is intended at an ambient temperature of +10°C with a water temperature of +10°C. Standard voltage is V230/50Hz single phase. Other voltages such as V230/60Hz and V115/60Hz single phase on request. Models and specifications may be subject to variations without prior notice.

Atención:
Las producciones en las 24h se consideran con una temperatura ambiente de +10°C y una temperatura del agua de +10°C. El voltaje estándar es V230/50Hz monofásico. Otros voltajes como V230/60Hz y V115/60Hz monofásico a petición.
Los modelos y las características pueden sufrir variaciones sin aviso previo.

Achtung:
Die Produktion innerhalb von 24 Stunden versteht sich bei einer Raumtemperatur von +10°C sowie einer Wassertemperatur von +10°C. Die Standardspannung beträgt V230/50Hz einphasig. Weitere Spannungswerte wie V230/60Hz und V115/60 Hz einphasig auf Anfrage. Die Modelle und Charakteristiken können Änderungen ohne Vorankündigung unterliegen.



Migel S.r.l. Viale Risorgimento, 28 - I - 20030 Senago (MI)
Tel. (+39) 02 99057727 - Fax (+39) 02 99056470 - e-mail: migel@migel-ice-line.com
www.migel-ice-line.com